

DLC Display Co., Limited

德爾西顯示器有限公司



MODEL No:DLC0700BAM24QT-R-2

TEL: 86-755-86029824

FAX: 86-755-86029827

E-MAIL: sales@dlcdisplay.com

WEB: www.dlcdisplay.com



Record of Revision

Date	Revision No.	Summary
2021-01-19	1.0	Rev 1.0 was issued

1. Scope

This data sheet is to introduce the specification of DLC0700BAM24QT-R-2 active matrix TFT module. It is composed of a color TFT-LCD panel, driver ICs, FPC, RTP and a backlight unit. The 7.0" display area contains 800(RGB) x 480 pixels.

2. Application

Digital equipments which need color display outdoor, mobile navigator/video systems.

3. General Information

Item	Contents	Unit
Size	7.0	inch
Resolution	800(RGB) x 480	/
Interface	24 bits RGB	/
Technology type	a-Si TFT	/
Pixel pitch	0.1926 x 0.1790	mm
Pixel Configuration	R.G.B. Vertical Stripe	
Outline Dimension (W x H x D)	164.90 x 100.00 x 7.20	mm
Active Area	154.08 x 85.92	mm
Display Mode	Transmissive, Normally white	/
Viewing Direction	12 o'clock	/
Display Driver IC	HX8264 & HX8664	/
Backlight Type	LED	/
Weight	TBD	g

4. Outline Drawing

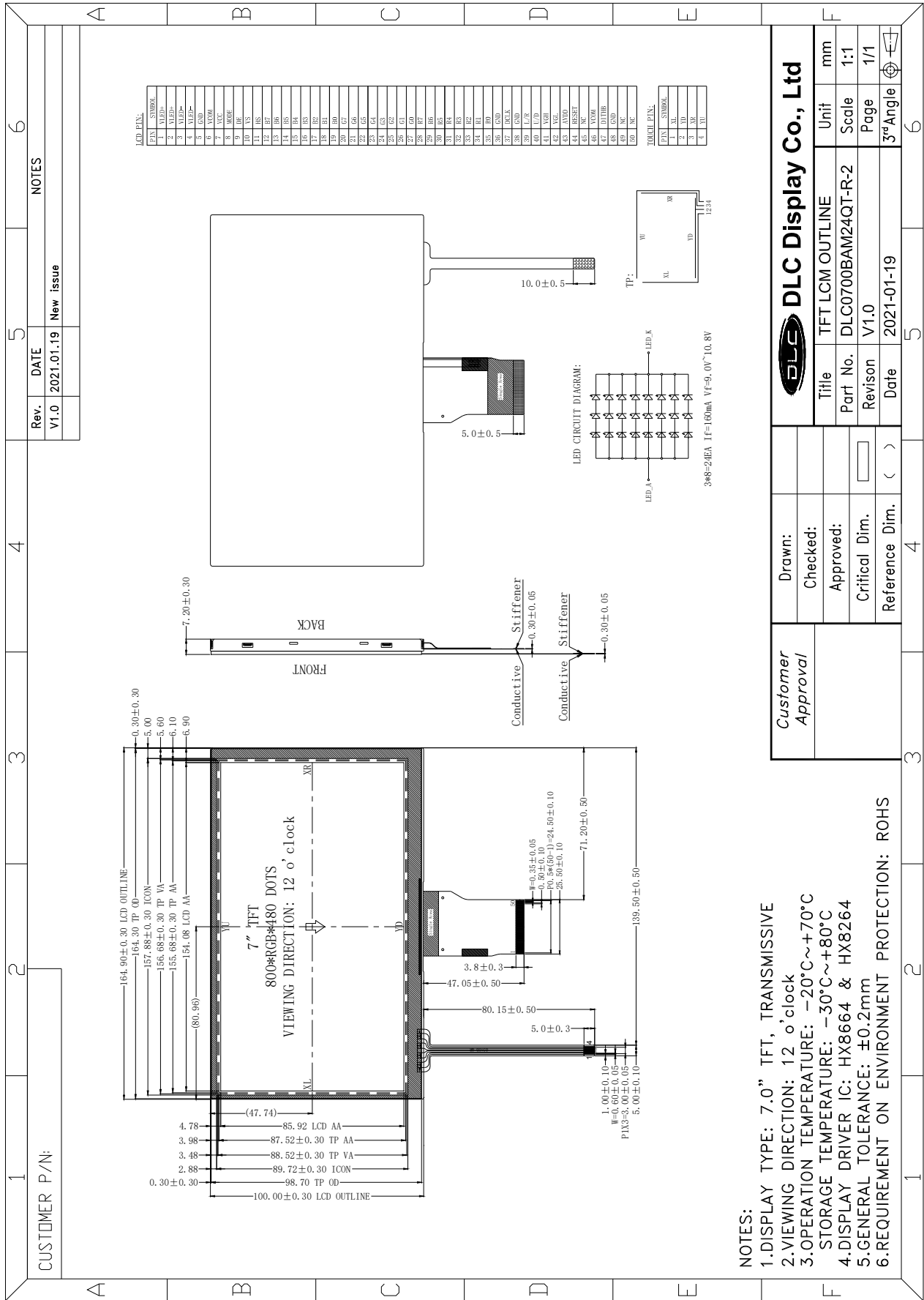

Customer Approval	Drawn:	DLC Display Co., Ltd					
	Checked:						
Approved:	Title				TFT LCM OUTLINE	Unit	mm
Critical Dim.	Part No.				DLC0700BAM24QT-R-2	Scale	1:1
Reference Dim.	Revision				V1.0	Page	1/1
	Date				2021-01-19	3rd Angle	

5. Interface signals

No	Symbol	Description	Remarks
1	VLED+	Power for LED Backlight (Anode)	
2	VLED+	Power for LED Backlight (Anode)	
3	VLED-	Power for LED Backlight (Cathode)	
4	VLED-	Power for LED Backlight (Cathode)	
5	GND	Power ground	
6	VCOM	For external VCOM DC input	
7	VCC	Power for digital circuit	
8	MODE	DE/SYNC mode select. Normally pull high MODE=1, DE mode, VS and HS must pull high; MODE=0, HSD/VSD mode, DE must be grounded	
9	DE	Data input enable	
10	VS	Vertical sync input	
11	HS	Horizontal sync input	
12	B7	Blue data (MSB)	
13	B6	Blue data	
14	B5	Blue data	
15	B4	Blue data	
16	B3	Blue data	
17	B2	Blue data	
18	B1	Blue data	
19	B0	Blue data (LSB)	
20	G7	Green data (MSB)	
21	G6	Green data	
22	G5	Green data	
23	G4	Green data	
24	G3	Green data	
25	G2	Green data	
26	G1	Green data	
27	G0	Green data (LSB)	
28	R7	Red data (MSB)	
29	R6	Red data	
30	R5	Red data	
31	R4	Red data	
32	R3	Red data	
33	R2	Red data	
34	R1	Red data	

35	R0	Red data (LSB)	
36	GND	Power ground	
37	DCLK	Sample clock Data shall be latched at the falling edge of DCLK	
38	GND	Power ground	
39	L/R	Left/Right selection	Note
40	U/D	Up/Down selection	Note
41	VGH	Gate on voltage	
42	VGL	Gate off voltage	
43	AVDD	Power for analog circuit	
44	RESET	Global reset pin Active low to enter reset state, suggest to connect with an RC reset circuit for stability. Normally pull high.	
45	NC	No connection	
46	VCOM	For external VCOM DC input	
47	DITHB	Dithering function enable control, Normally pull high When DITHB=1, disable internal dithering function; When DITHB=0, enable internal dithering function.	
48	GND	Power ground	
49	NC	No connection	
50	NC	No connection	

Notes:

1. Matched connector: FH12A-50S-0.5H
2. U/D R/L Function Description

Scan Control Input		Scanning Direction
U/D	L/R	
GND	VCC	Up to Down, Left to Right
VCC	GND	Down to Up, Right to Left
GND	GND	Up to Down, Right to Left
VCC	VCC	Down to Up, Left to Right

Touch Pin Definition:

No	Symbol	Description	Remarks
1	XL	Touch panel control pin, Left	
2	YD	Touch panel control pin, Down	
3	XR	Touch panel control pin, Right	
4	YU	Touch panel control pin, Up	

6. Absolute maximum Ratings

6.1. Electrical Absolute max. ratings

Parameter	Symbol	MIN	MAX	Unit	Remark
Power Voltage	VCC	-0.5	3.96	V	
	AVDD	-0.5	14.85	V	
	VGH	-0.3	42	V	
	VGL	-20	0.3	V	
	VGH-VGL	-0.3	40	V	
Single input voltage	Vin	-0.5	5.0	V	Note

Note: Input voltage include R0~R7, G0~G7, B0~B7, DCLK, HSYNC, VSYNC, DE, R/L, U/D, MODE, RESET, DITHB.

6.2. Environment Conditions

Item	Symbol	MIN	MAX	Unit	Remark
Operating Temperature	TOPR	-20	70	°C	
Storage Temperature	TSTG	-30	80	°C	

7. Electrical Specifications

7.1 Electrical characteristics

AGND=GND=0V, Ta=25°C

Item	Symbol	MIN	TYP	MAX	Unit	Remark
Digital supply voltage	VCC	3.0	3.3	3.6	V	
Analog supply voltage	AVDD	10.1	10.4	10.7	V	
Gate on voltage	VGH	14.4	16.0	17.6	V	
Gate off voltage	VGL	-7.7	-7.0	-6.3	V	
Common electrode driving signal	VCOM	3.85	3.95	4.05	V	
Input signal voltage	Low level	VIL	0	-	0.3*VCC	R0~R7, G0~G7, B0~B7, DE, DCLK, HSYNC, VSYNC, MODE, RESET, LR, UD, DITHB
	High level	VIH	0.7*VCC	-	VCC	
Current of digital supply voltage	IVCC	-	-	10	mA	VCC=3.3V, Black pattern
Current of analog supply voltage	I _{AVDD}	-	-	30	mA	
Current of Gate on voltage	I _{VGH}	-	-	0.3	mA	VGH=16.0V
Current of Gate off voltage	I _{VGL}	-	-	0.3	mA	VGL= -7.0V

Note : It is necessary to keep the input voltage within the suggested range.

7.2 LED Backlight

Ta=25°C

Item	Symbol	MIN	TYP	MAX	Unit	Remark
Forward Current	IF	--	160	200	mA	24LEDs (3 LED serial, 8 LED Parallel)
Forward Voltage	VF	9.0	9.6	10.8	V	
Operating Life Time	-	20,000	-	-	Hrs	

Notes:

1. The LED driving condition is defined for each module (3 LED Serial, 8 LED Parallel).
2. Under LCM operating, the stable forward current should be inputted. And forward voltage is for reference only.
3. IF is defined for six channel LED. Optical performance should be evaluated at Ta=25°C, When LED is driven by high current, high ambient temperature & humidity condition. The life time of LED will be reduced. Operating life means brightness goes down to 50% initial brightness. Typical operating life time is estimated data.
4. The LED driving condition is defined for each LED module.

LED CIRCUIT DIAGRAM:

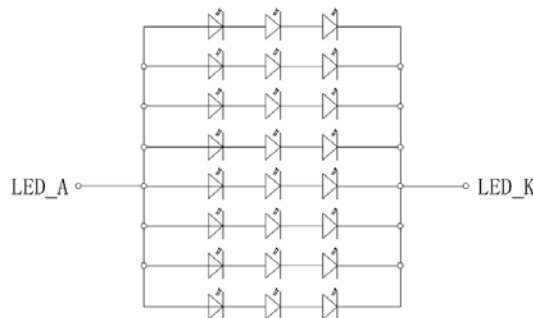

$3 \times 8 = 24EA$ $I_f = 160mA$ $V_f = 9.0V \sim 10.8V$

7.3 Block Diagram of LCM

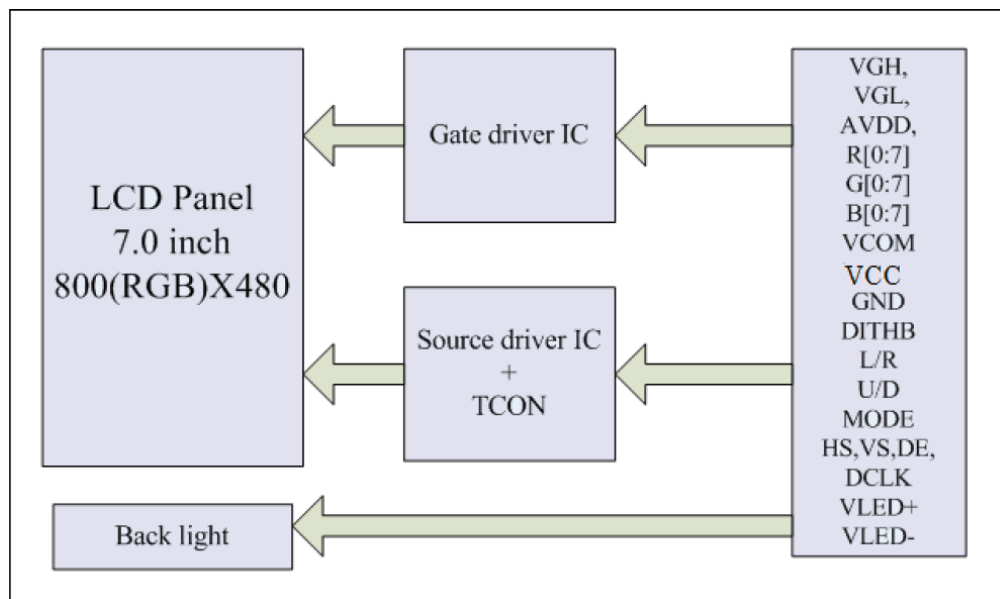

8. Command/AC Timing

8.1 TFT-LCD Input Timing

VCC=3.3V, AVDD=10.4V, AGND=GND=0V, Ta=25°C

Parameter	Symbol	Min	Typ	Max	Unit	Conditions
DCLK Frequency	Fclk	26.5	33.3	46.8	MHz	
DCLK Cycle Time	Tcph	21.4	30	37.7	ns	
DCLK Pulse Width	Tcwh	40%	50%	60%	%	
VS Setup Time	Tvst	8	-	-	ns	
VS Hold Time	Tvhd	8	-	-	ns	
HS Setup Time	Thst	8	-	-	ns	
HS Hold Time	Thhd	8	-	-	ns	
Data Setup Time	Tdsu	8	-	-	ns	Data to DCLK
Data Hold Time	Tdhd	8	-	-	ns	Data to DCLK
DE Setup Time	Tesu	8	-	-	ns	
DE Hold Time	Tehd	8	-	-	ns	

Input Clock and Data timing Diagram

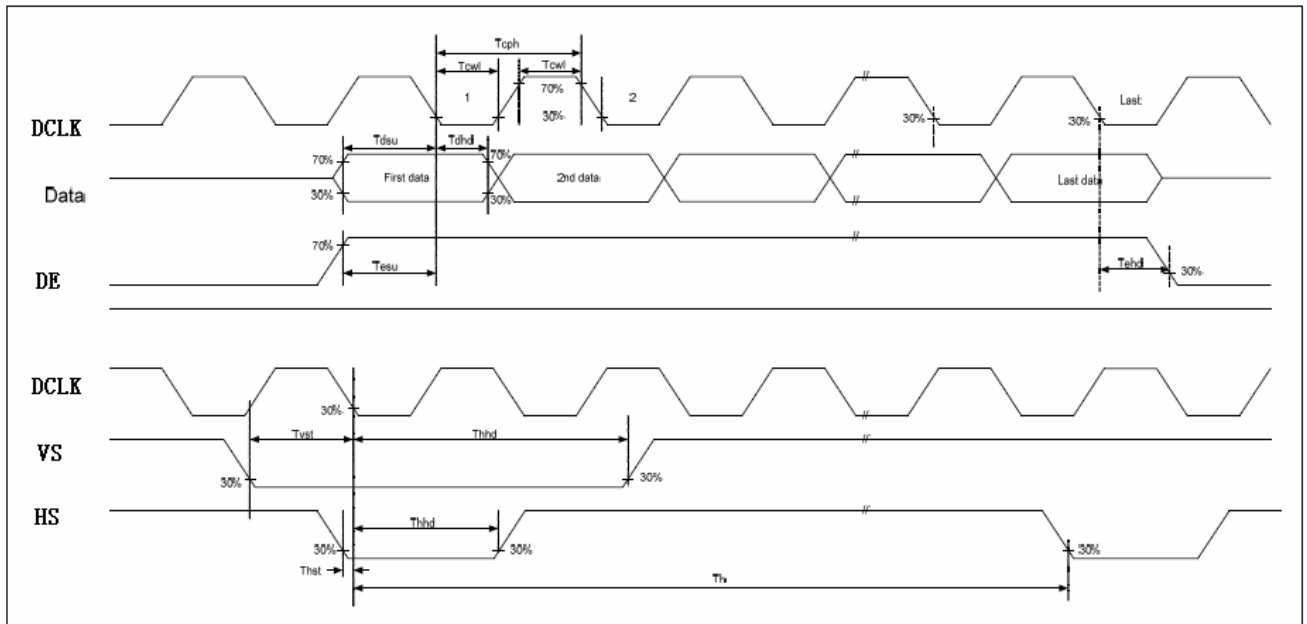

8.2 Recommended Timing Setting of TCON

TCON (Embedded In Source IC) Input Timing (DCLK, HS, VS, DE)

VCC=3.3V, AVDD=10.4V, AGND=GND=0V, Ta=25°C

Parameter	Symbol	Min.	Typ.	Max.	Unit	Remark
DCLK	fclk	26.5	33.3	46.8	MHZ	
	tclk	21.4	30	37.7	ns	
HS	th	862	1056	1200	DCLK	
	thd	800			DCLK	
	thpw	1	-	40	DCLK	
	thb	46	46	46	DCLK	
	thfp	16	210	354	DCLK	
VS	tv	513	525	650	th	
	tvd	480			th	
	tvpw	3	-	20	th	
	tvb	23	23	23	th	
	tvfp	7	22	147	th	

Note: DE timing refer to HS, VS input timing.

Vertical input timing Diagram

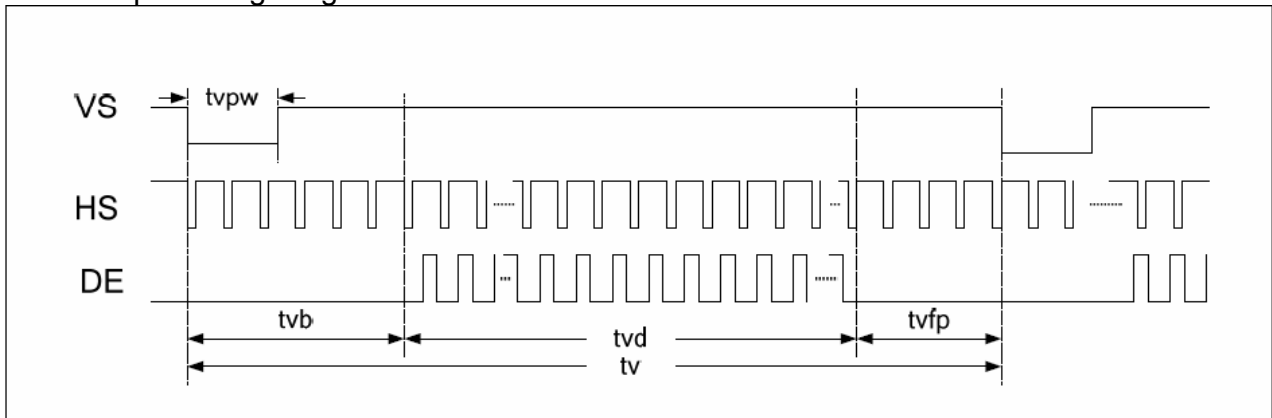

Horizontal input timing Diagram

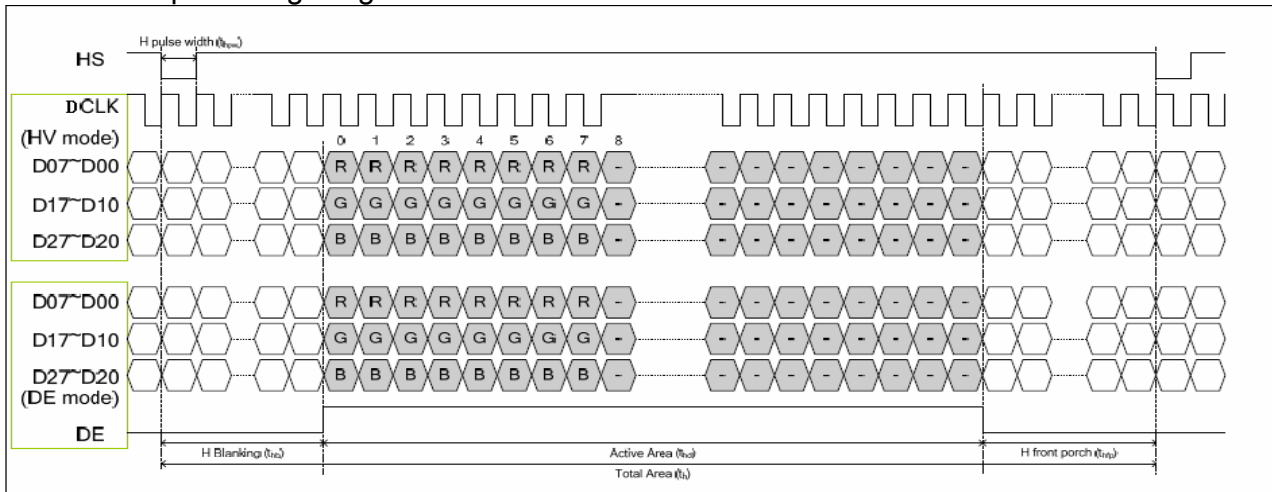

8.3 Power ON/OFF Sequence

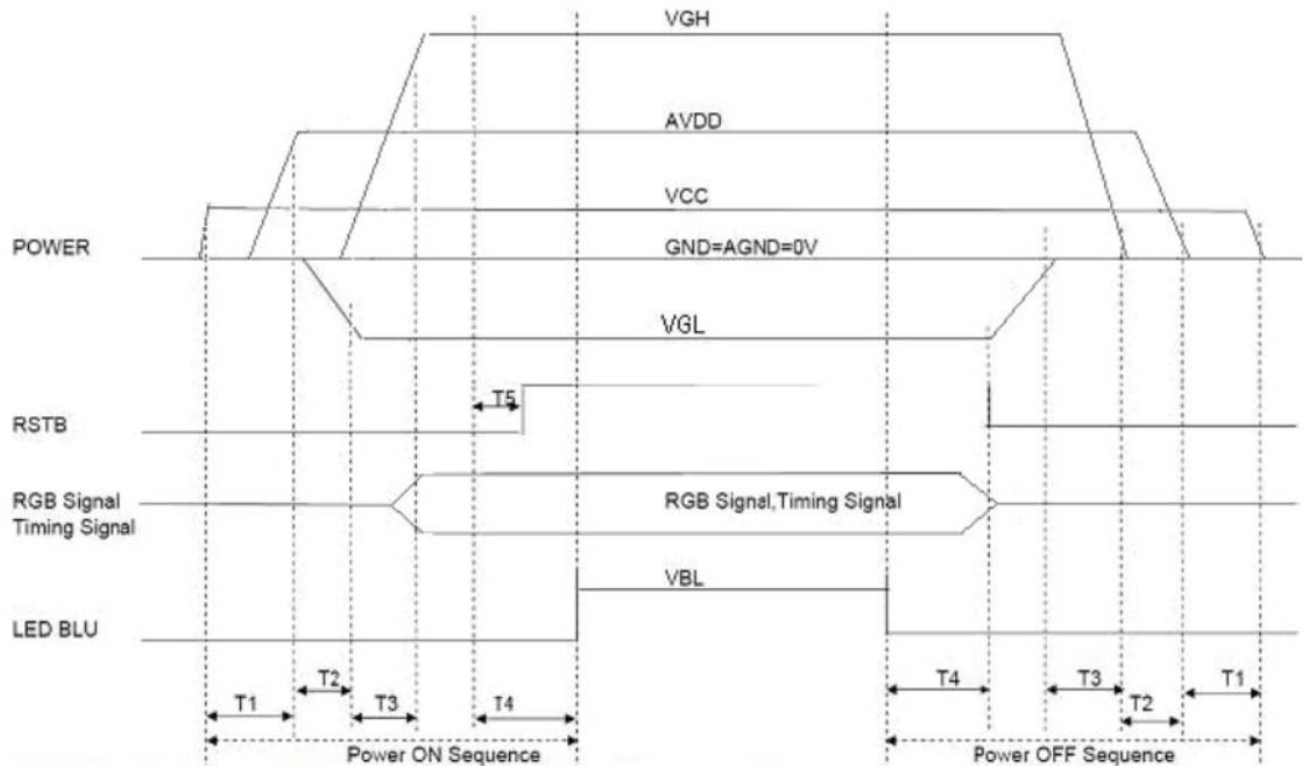

Note: $T1 \geq 20\text{ms}$, $T2 \geq 20\text{ms}$, $T3 \geq 5\text{ms}$, $T4 \geq 100\text{ms}$, $T5 \geq 5\text{ms}$.

9. Optical Specification

Item	Symbol	Condition	Min	Typ.	Max.	Unit	Remark		
Contrast Ratio	CR	$\theta=0^\circ$	600	800	-		Note1 Note2		
Response Time	Tr+Tf	25°C	-	25	-	ms	Note1 Note3		
View Angles	ΘT	CR ≥ 10	50	60	-	Degree	Note 4		
	ΘB		60	80	-				
	ΘL		60	80	-				
	ΘR		60	80	-				
Chromaticity	White	Brightness is on	Typ-0.05	Typ+0.05			Note5, Note1		
								x	0.309
	y							0.318	
	Red							x	0.588
								y	0.352
	Green							x	0.348
								y	0.581
	Blue							x	0.150
y		0.086							
NTSC			-	50	-	%	Note5		
Luminance	L		-	320	-	cd/m ²	Note1 Note6		
Uniformity (White)	U		80	85	-	%	Note1 Note7		

Note 1: Definition of optical measurement system.

Temperature = 25°C(±3°C)

LED back-light: ON, Environment brightness < 150 lx

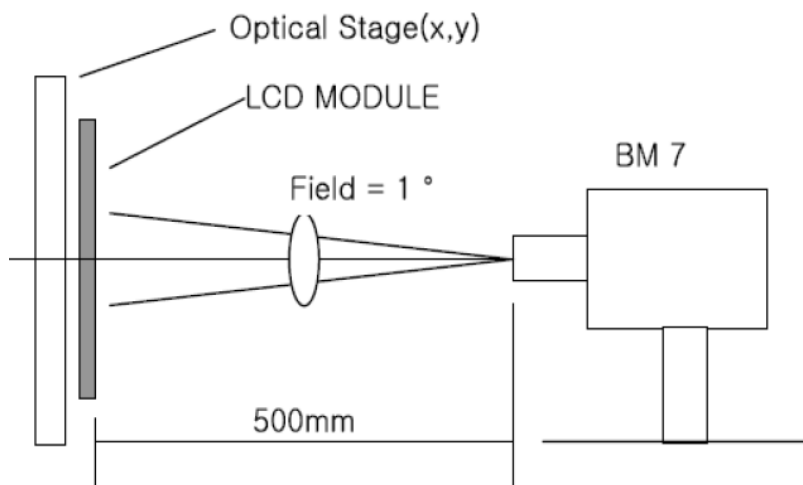

Note 2: Contrast ratio is defined as follow:

$$\text{Contrast Ratio} = \frac{\text{Surface Luminance with all white pixels}}{\text{Surface Luminance with all black pixels}}$$

Note 3: Response time is defined as follow:

Response time is the time required for the display to transition from black to white (Rise Time, T_r) and from white to black (Decay Time, T_f).

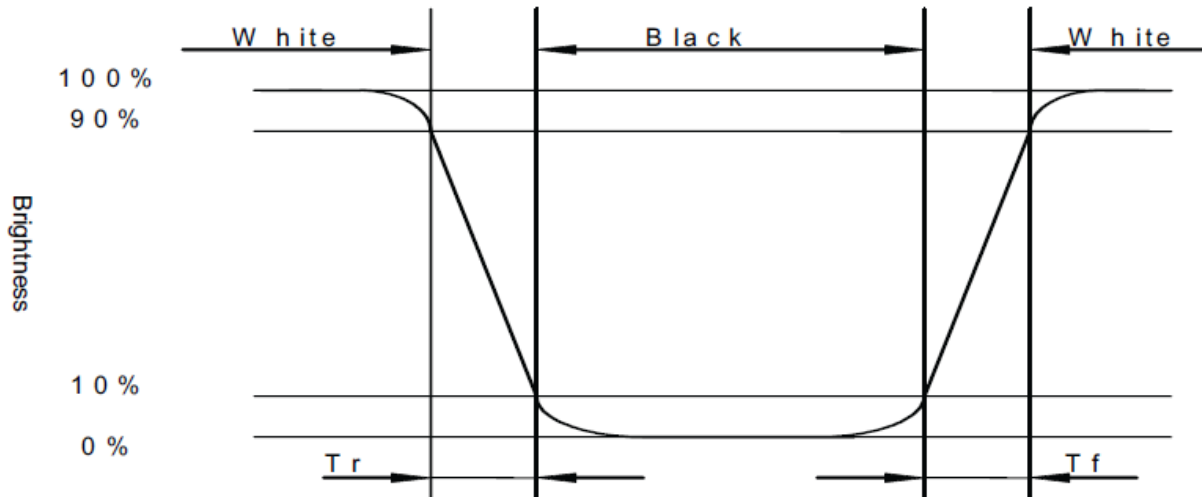

Note 4: Viewing angle range is defined as follow:

Viewing angle is measured at the center point of the LCD.

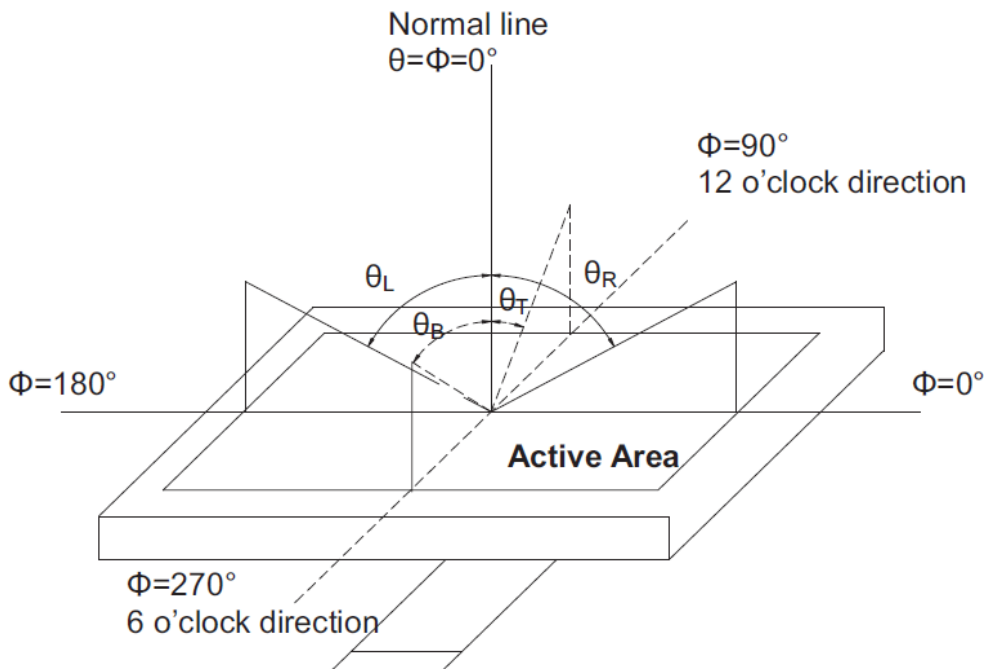

Note 5: Color chromaticity is defined as follow: (CIE1931)

Color coordinates measured at center point of LCD.

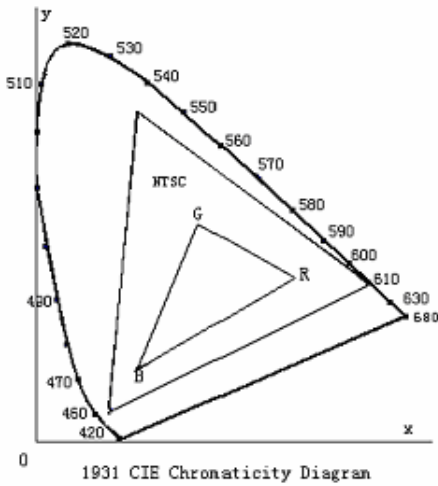

$$S = \frac{\text{area of RGB triangle}}{\text{area of NTSC triangle}} \times 100\%$$

Note 6: Luminance is defined as follow:

Luminance is defined as the brightness of all pixels “White” at the center of display area on optimum contrast.

Note 7: Luminance Uniformity is defined as follow:

Active area is divided into 9 measuring areas (Refer Fig. 2). Every measuring point is placed at the center of each measuring area.

$$\text{Uniformity (U)} = \frac{\text{Minimum Luminance(brightness) in 9 points}}{\text{Maximum Luminance(brightness) in 9 points}}$$

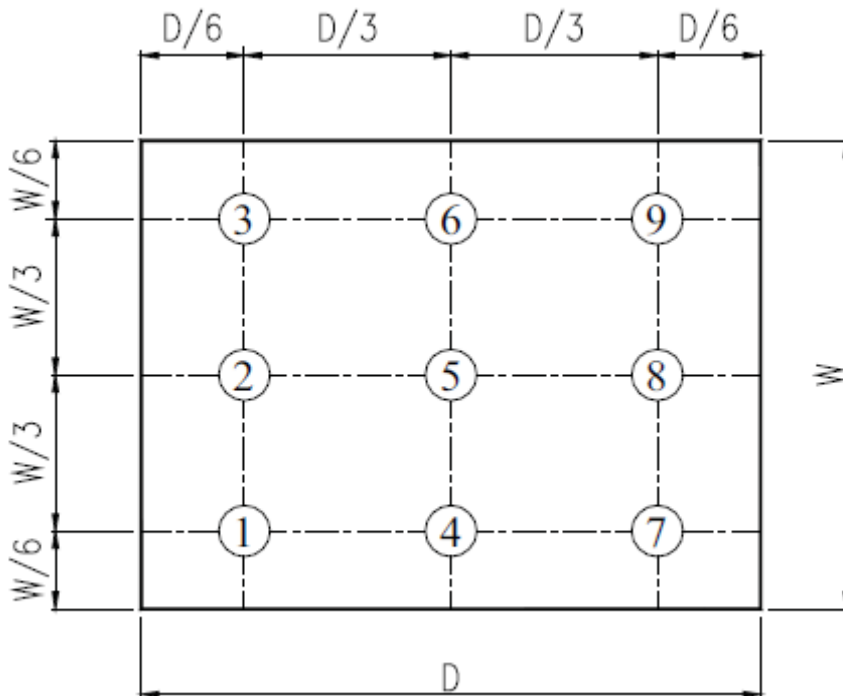

Fig. 2 Definition of uniformity

10. Environmental / Reliability Tests

No	Test Item	Condition	Judgment criteria
1	High Temp Operation	Ta=+70°C, 240hrs	Per table in below
2	Low Temp Operation	Ta=-20°C, 240hrs	Per table in below
3	High Temp Storage	Ts=+80°C, 240hrs	Per table in below
4	Low Temp Storage	Ts=-30°C, 240hrs	Per table in below
5	High Temp & High Humidity Storage	Ts=+60°C, 90% RH, 240 hours	Per table in below (polarizer discoloration is excluded)
6	Thermal Shock (Non-operation)	-30°C 30 min~+80°C 30 min, Change time:5min, 10 Cycles	Per table in below
7	ESD (Operation)	C=150pF, R=330Ω · 5points/panel Air:±8KV, 5times; Contact:±4KV, 5 times;	Per table in below
8	Vibration (Non-operation)	Frequency range:10~55Hz, Stroke:1.5mm Sweep:10Hz~55Hz~10Hz 2 hours for each direction of X.Y.Z.	Per table in below
9	Shock (Non-operation)	60G 6ms, ±X,±Y,±Z 3times, for each direction	Per table in below
10	Package Drop Test	Height:80 cm, 1 corner, 3 edges, 6 surfaces	Per table in below

INSPECTION	CRITERION(after test)
Appearance	No Crack on the FPC, on the LCD Panel
Alignment of LCD Panel	No Bubbles in the LCD Panel No other Defects of Alignment in Active area
Electrical current	Within device specifications
Function / Display	No Broken Circuit, No Short Circuit or No Black line No Other Defects of Display

11. Precautions for Use of LCD Modules

11.1 Safety

The liquid crystal in the LCD is poisonous. Do not put it in your mouth. If the liquid crystal touches your skin or clothes, wash it off immediately using soap and water.

11.2 Handling

- A. The LCD and touch panel is made of plate glass. Do not subject the panel to mechanical shock or to excessive force on its surface.
- B. Do not handle the product by holding the flexible pattern portion in order to assure the reliability
- C. Transparency is an important factor for the touch panel. Please wear clear finger sacks, gloves and mask to protect the touch panel from finger print or stain and also hold the portion outside the view area when handling the touch panel.
- D. Provide a space so that the panel does not come into contact with other components.
- E. To protect the product from external force, put a covering lens (acrylic board or similar board) and keep an appropriate gap between them.
- F. Transparent electrodes may be disconnected if the panel is used under environmental conditions where dew condensation occurs.
- G. Property of semiconductor devices may be affected when they are exposed to light, possibly resulting in IC malfunctions.
- H. To prevent such IC malfunctions, your design and mounting layout shall be done in the way that the IC is not exposed to light in actual use.

11.3 Static Electricity

- A. Ground soldering iron tips, tools and testers when they are in operation.
- B. Ground your body when handling the products.
- C. Power on the LCD module before applying the voltage to the input terminals.
- D. Do not apply voltage which exceeds the absolute maximum rating.
- E. Store the products in an anti-electrostatic bag or container.

11.4 Storage

- A. Store the products in a dark place at $+25^{\circ}\text{C} \pm 10^{\circ}\text{C}$ with low humidity (40% RH to 60% RH). Don't expose to sunlight or fluorescent light.
- B. Storage in a clean environment, free from dust, active gas, and solvent.

11.5 Cleaning

- A. Do not wipe the touch panel with dry cloth, as it may cause scratch.
- B. Wipe off the stain on the product by using soft cloth moistened with ethanol. Do not allow ethanol to get in between the upper film and the bottom glass. It may cause peeling issue or defective operation. Do not use any organic solvent or detergent other than ethanol.

11.6 Cautions for installing and assembling

- A. Bezel edge must be positioned in the area between the Active area and View area. The bezel may press the touch screen and cause activation if the edge touches the active area. A gap of approximately 0.5mm is needed between the bezel and the top electrode. It may cause unexpected activation if the gap is too narrow. There is a tolerance of 0.2 to 0.3mm for the outside dimensions of the touch panel and tail. A gap must be made to absorb the tolerance in the case and connector.
- B. In order to make the display assembly stable and firm, DLC recommends to design some supporting at the display backside, especially for the display with tape-attached touch panel, such supporting is important and essential, or else, the display may drop-off from front after some period of time.
- C. Do not display the fixed pattern for a long time because it may develop image sticking due to the LCD structure. If the screen is displayed with fixed pattern, use a screen saver.

